

Bomba hidráulica con freno mini

ref: B13

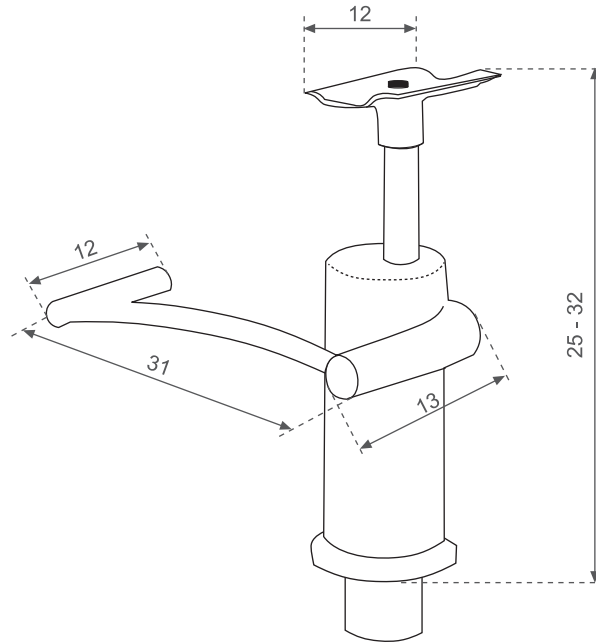

ESPECIFICACIONES DEL ARTÍCULO / GOOD SPECIFICATIONS / SPECIFICACIONE MERCI

Ancho Widht Larghezza	cm	Alto Height Altezza	cm	Fondo Lenght Lunghezza	cm	Peso Neto Net Weight Peso Netto	kg	N° de bultos N. of packages N° dei Colii
12,2		25 - 32		31		5,5		1

ESPECIFICACIONES DEL EMBALAJE / PACKAGING SPECIFICATIONS / SPECIFICACIONE IMBALAGGIO

Ancho Widht Larghezza	cm	Alto Height Altezza	cm	Fondo Lenght Lunghezza	cm	Peso Bruto Gross Weight Peso Lordo	kg	Bulto Package Pachetto	Contenido Content Contenuto	CBM
16		34		41		6		1	B13	0,022

OBSERVACIONES / COMMENTS / COMMENTI

- Freno.
- Pedal aluminio.