

# Bomba eléctrica

ref: B61

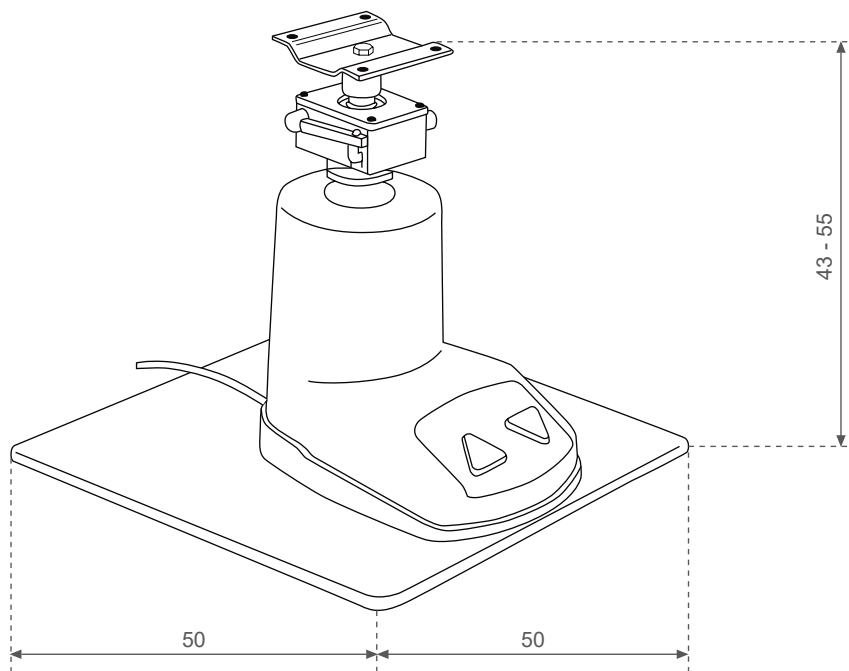

## ESPECIFICACIONES DEL ARTÍCULO / GOOD SPECIFICATIONS / SPECIFICACIONE MERCI

Ancho Widht Larghezza	cm	Alto Height Altezza	cm	Fondo Lenght Lunghezza	cm	Peso Neto Net Weight Peso Netto	kg	N° de bultos N. of packages N° dei Colii
50		43 - 55		50		26,5		1

## ESPECIFICACIONES DEL EMBALAJE / PACKAGING SPECIFICATIONS / SPECIFICACIONE IMBALAGGIO

Ancho Widht Larghezza	cm	Alto Height Altezza	cm	Fondo Lenght Lunghezza	cm	Peso Bruto Gross Weight Peso Lordo	kg	Bulto Package Pachetto	Contenido Content Contenuto	CBM
69		49		69		29,5		1	B61	0,233

## OBSERVACIONES / COMMENTS / COMMENTI

- Voltaje: 220V - 230V.
- Frecuencia: 50 - 60 Hz.
- Dispone de enchufe para conectar varias unidades en serie.
- Sistema mecánico de freno.